

3/S1
v 3.3 (en)

JET NOZZLES

SAP-F, SAP-Z



TABLE OF CONTENTS

Jet nozzles SAP-Z.....	193
Jet nozzles SAP-F.....	194
Selection diagrams.....	196
Motor drive.....	202

Definition of symbols:

V [m ³ /h]	- Airflow rate	H_{uk} [m]	- Installation height
y [m]	- Jet deflection	α [°]	- Angle of deflection
A [m]	- Horizontal difference between nozzle and point of jet collision	v_L [m/s]	- Medium air velocity at a point of jet collision
B [m]	- Distance between two nozzles in row	v_{H1} [m/s]	- Average air velocity at occupied zone
L [m]	- Throw distance	Δt_{H1} [K]	- Temperature difference between supply air at throw distance and room temperature
L_{max} [m/s]	- Total air throw of isothermal vertical jet	Δt_L [K]	- Difference between core and room temperature
H_1 [m]	- Distance from occupied zone to collision point of two cold jet		
H_2	- Distance from occupied zone to collision point of two warm jet		

SAP - Z

- For air supply with large throw distance and low noise requirements
- Made of anodized aluminium, standard powder coating in RAL 9010.
- Adjustable discharge angle ($\pm 30^\circ$)

Options

- RAL...
- Motor drive

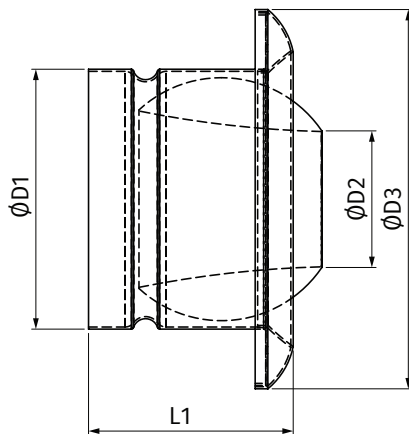

Dimensions	Ø D1 [mm]	Ø D2 [mm]	Ø D3 [mm]	L1 [mm]
100	101	48	148	79
125	126	60	170	89
160	159	76	200	118
200	203	96	265	138
250	248	127	309	178
315	317	180	378	195
400	396	220	466	214

Fast selection table SAP-Z

	ØD2	V (m ³ /h)	v _{ef} (m/s)	L (m)	L _{WA} (dB(A))	v _L (m/s)	V (m ³ /h)	v _{ef} (m/s)	L (m)	L _{WA} (dB(A))	v _L (m/s)	V (m ³ /h)	v _{ef} (m/s)	L (m)	L _{WA} (dB(A))	v _L (m/s)
100	50	47	6,62	10 m	<20	0,25 m/s	94	13,24	20 m	31	0,25 m/s	140	19,86	30 m	42	0,25 m/s
125	64	61	5,28		<20		122	10,57		27		180	15,54		37	
160	82	83	4,36		<20		166	8,71		<20		248	13,07		32	
200	108	104	3,17		<20		220	6,66		<20		306	9,28		25	
250	136	133	2,55		<20		274	5,23		<20		382	7,30		23	
315	174	180	2,10		<20		353	4,12		<20		540	6,31		21	
400	230	234	1,56		<20		464	3,10		<20		702	4,69		<20	

	ØD2	V (m ³ /h)	v _{ef} (m/s)	L (m)	L _{WA} (dB(A))	v _L (m/s)	V (m ³ /h)	v _{ef} (m/s)	L (m)	L _{WA} (dB(A))	v _L (m/s)	V (m ³ /h)	v _{ef} (m/s)	L (m)	L _{WA} (dB(A))	v _L (m/s)
100	50	94	13,24	10 m	31	0,5 m/s	187	26,48	20 m	51	0,5 m/s	187	26,48	30 m	51	0,5 m/s
125	64	122	10,57		27		245	21,14		46		306	26,42		51	
160	82	166	8,71		<20		331	17,42		39		497	26,13		50	
200	108	220	6,66		<20		436	13,21		36		655	19,87		47	
250	136	274	5,23		<20		547	10,46		32		824	15,76		43	
315	174	353	4,12		<20		702	8,20		27		1055	12,32		39	
400	230	464	3,10		<20		929	6,21		27		1393	9,31		37	

SAP - F

- For air supply with large throw distance and low noise requirements
- Made of anodized aluminium, standard powder coating in RAL 9010.

Options

- RAL...

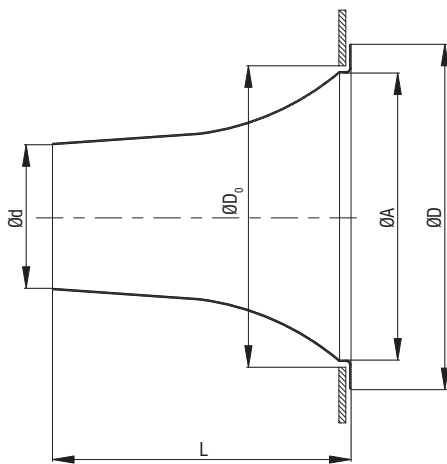

SAP-F	Ød [mm]	ØD [mm]	ØD ₀ [mm]	ØA [mm]	L [mm]	A _{ef} [m ²]
	50	130	105	100	105	0,002
	75	180	156	150	157	0,004
	100	240	210	200	210	0,007
	125	330	295	285	240	0,012
	150	350	310	300	290	0,017
	175	350	310	300	190	0,024
	200	510	460	450	380	0,031

Fast selection table SAP-F

	V (m ³ /h)	v _{ef} (m/s)	L (m)	L _{WA} (dB(A))	v _L (m/s)	V (m ³ /h)	v _{ef} (m/s)	L (m)	L _{WA} (dB(A))	v _L (m/s)	V (m ³ /h)	v _{ef} (m/s)	L (m)	L _{WA} (dB(A))	v _L (m/s)
50	47	6,65	10 m	<20	0,25 m/s	94	13,30	20 m	31	0,25 m/s	140	19,81	30 m	42	0,25 m/s
75	76	4,78		<20		150	9,43		24		223	14,02		35	
100	97	3,43		<20		195	6,90		<20		324	11,46		28	
125	130	2,94		<20		263	5,95		<20		367	8,31		24	
150	137	2,15		<20		288	4,53		<20		430	6,76		22	
175	170	1,96		<20		355	4,10		<20		558	6,44		20	
200	205	1,81		<20		432	3,82		<20		630	5,57		20	

	V (m ³ /h)	v _{ef} (m/s)	L (m)	L _{WA} (dB(A))	v _L (m/s)	V (m ³ /h)	v _{ef} (m/s)	L (m)	L _{WA} (dB(A))	v _L (m/s)	V (m ³ /h)	v _{ef} (m/s)	L (m)	L _{WA} (dB(A))	v _L (m/s)
50	94	13,30	10 m	31	0,5 m/s	187	26,46	20 m	51	0,5 m/s	187	26,46	30 m	51	0,5 m/s
75	155	9,75		25		306	19,24		42		418	26,28		50	
100	225	7,96		<20		432	15,28		37		612	21,65		49	
125	270	6,11		<20		486	11,00		34		756	17,11		45	
150	295	4,64		<20		594	9,34		30		900	14,15		42	
175	360	4,16		<20		706	8,15		27		1062	12,26		39	
200	432	3,82		<20		468	4,14		27		1152	10,19		38	

Isothermal air jet

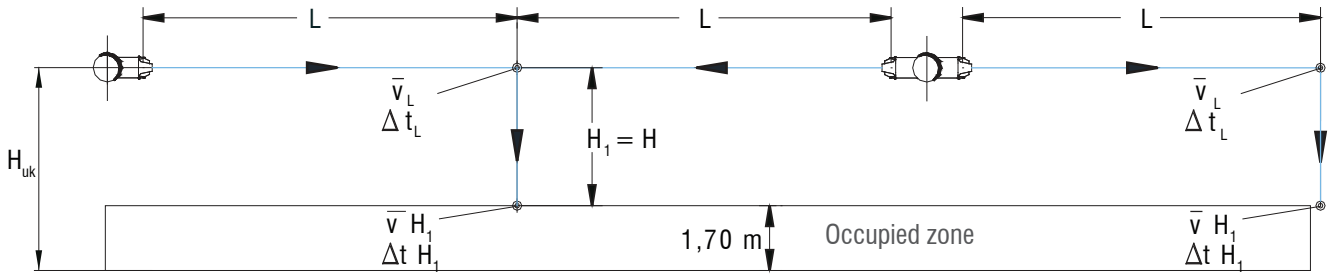

Cold air jet

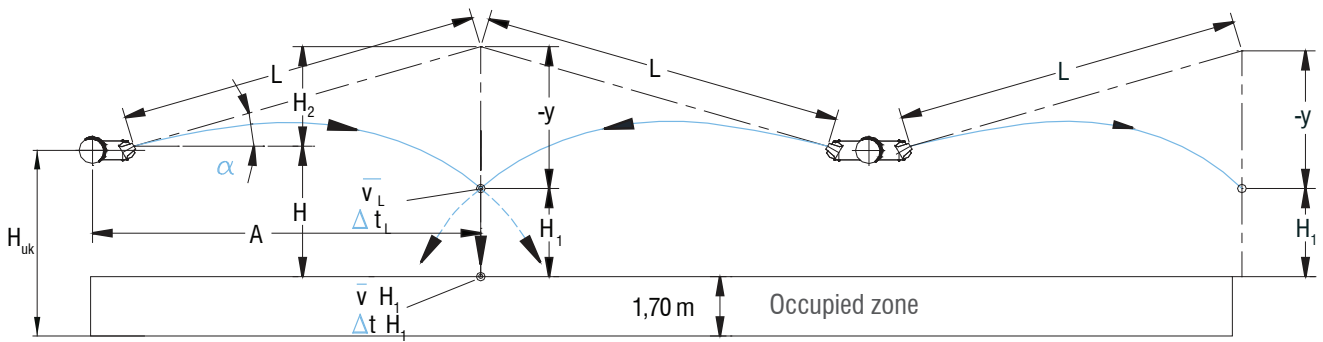

Warm air jet

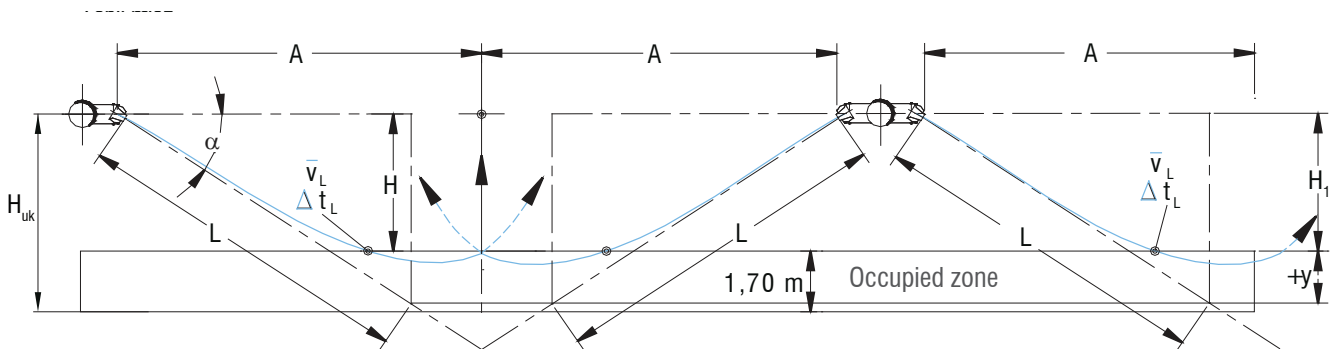

JET NOZZLES

SELECTION DIAGRAMS

Horizontal isothermal air jet SAP-F

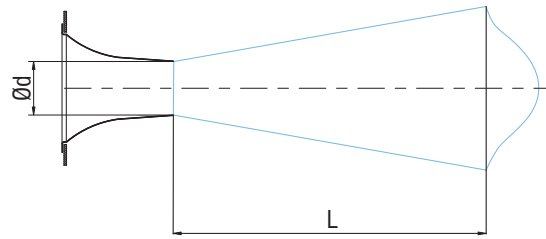
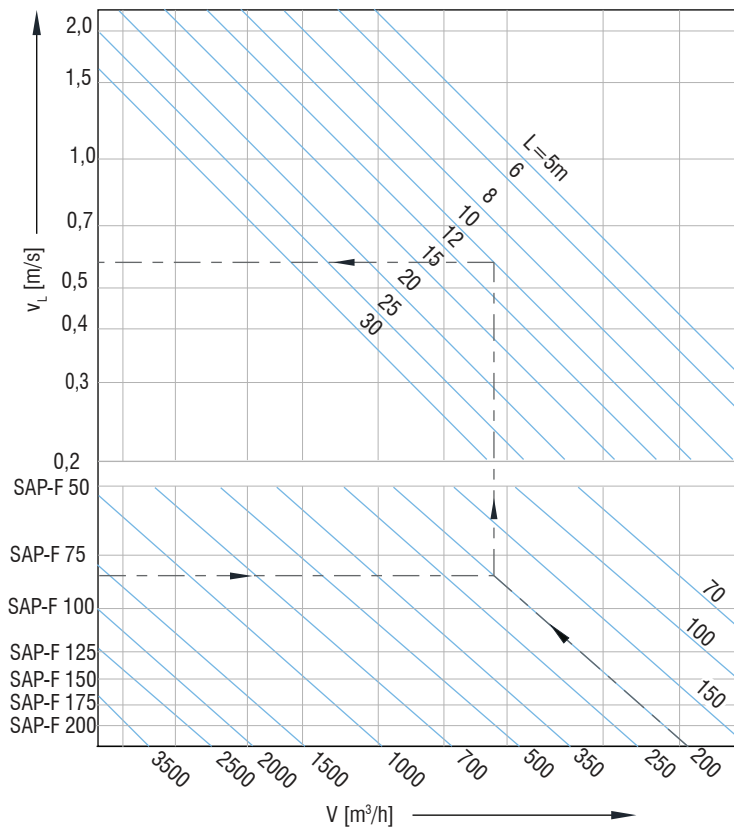

Horizontal isothermal air jet SAP-Z

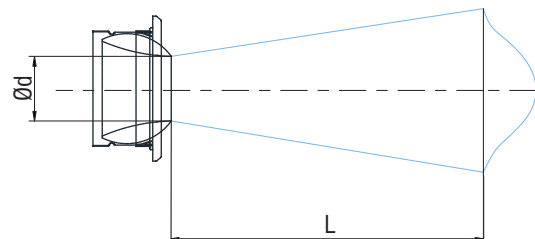
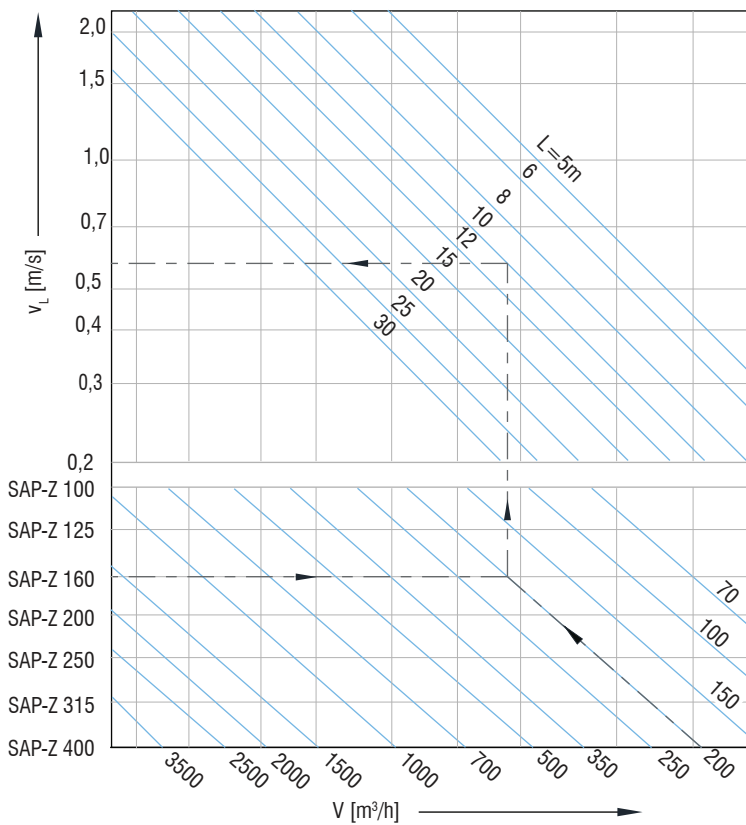

Vertical warm air jet SAP-F

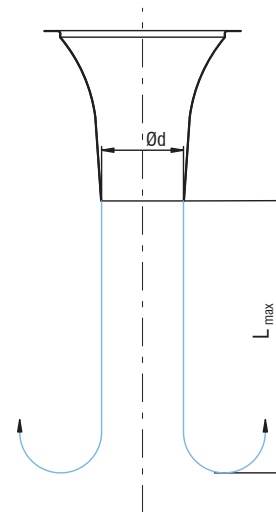
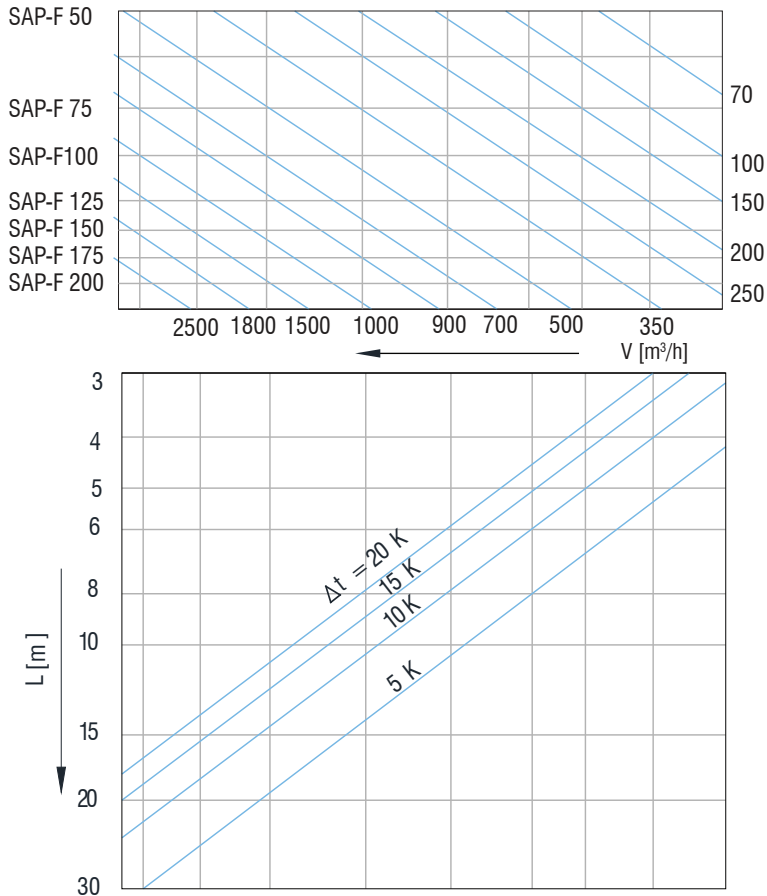

Vertical warm air jet SAP-Z

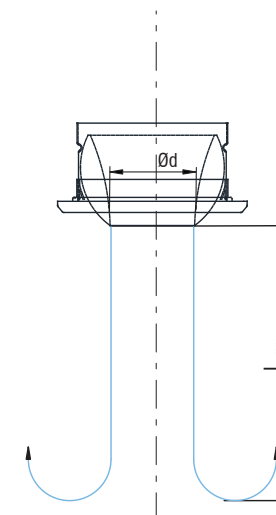
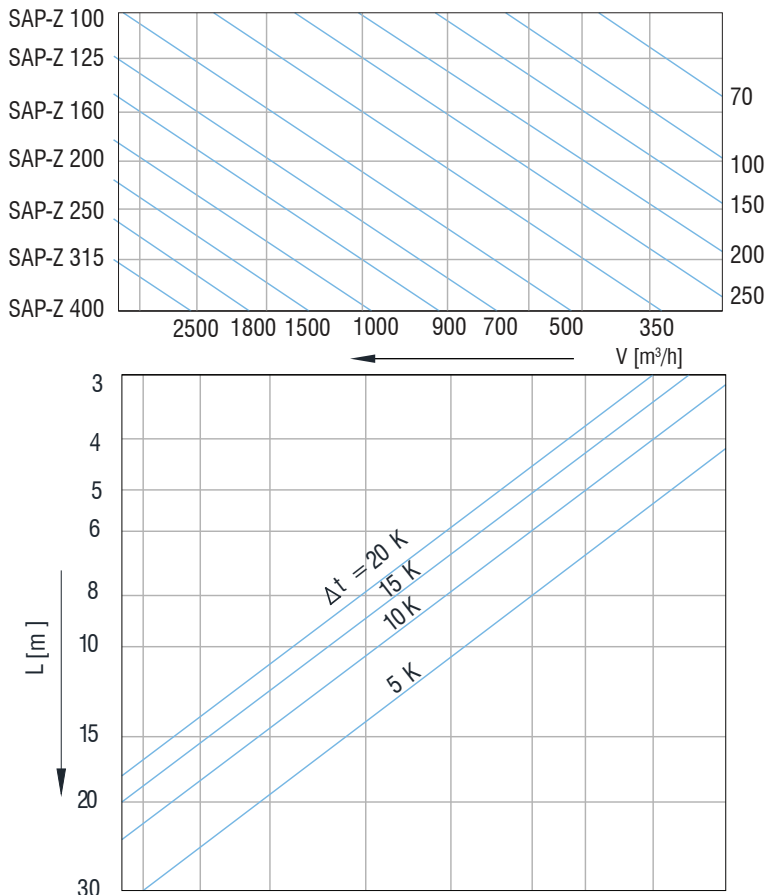

JET NOZZLES

Horizontal non isothermal air jet deflection SAP-F

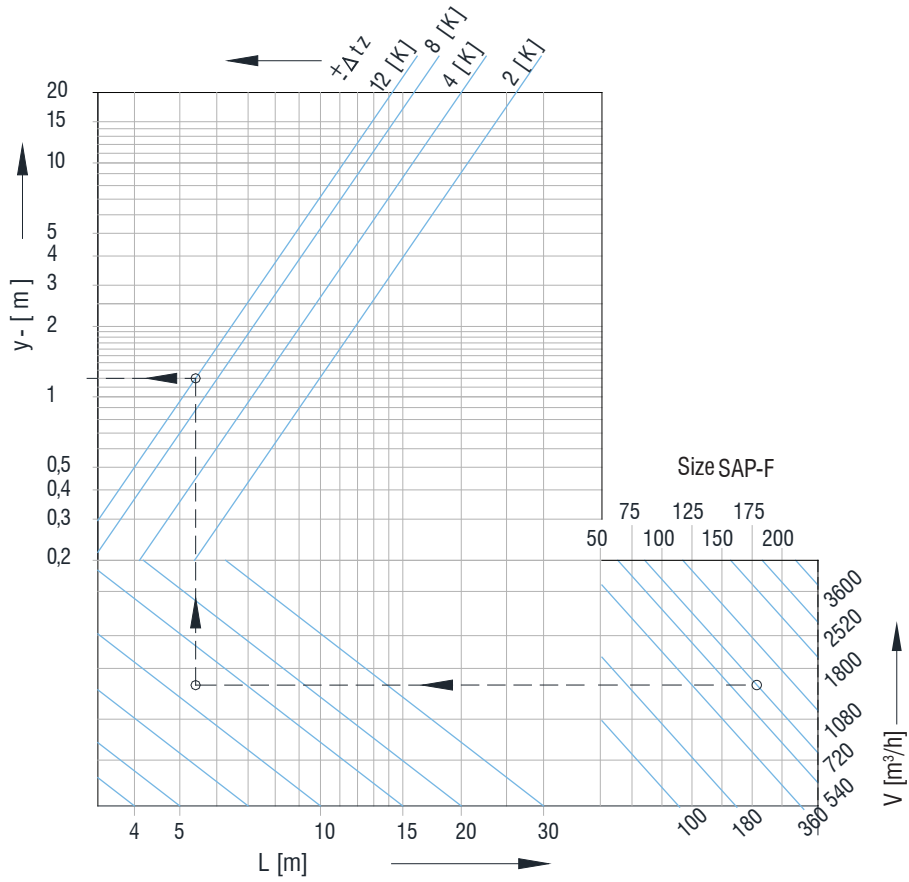

Horizontal non isothermal air jet deflection SAP-Z

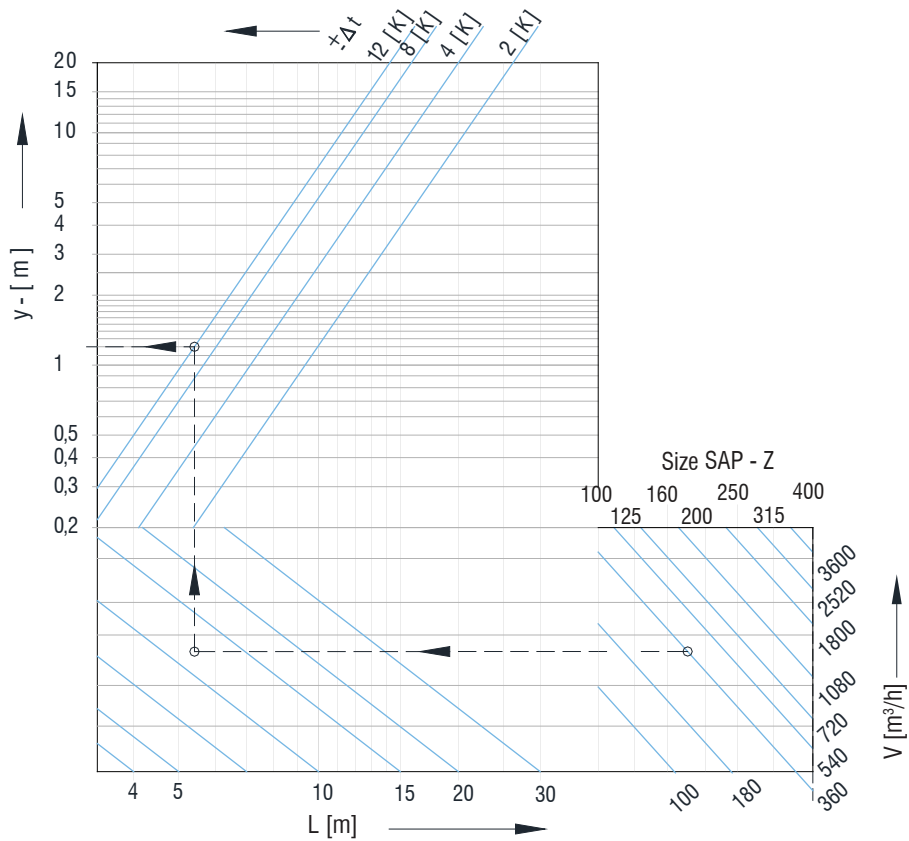

Axial installation SAP-F

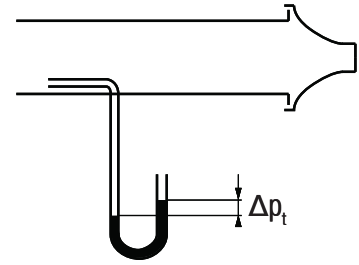
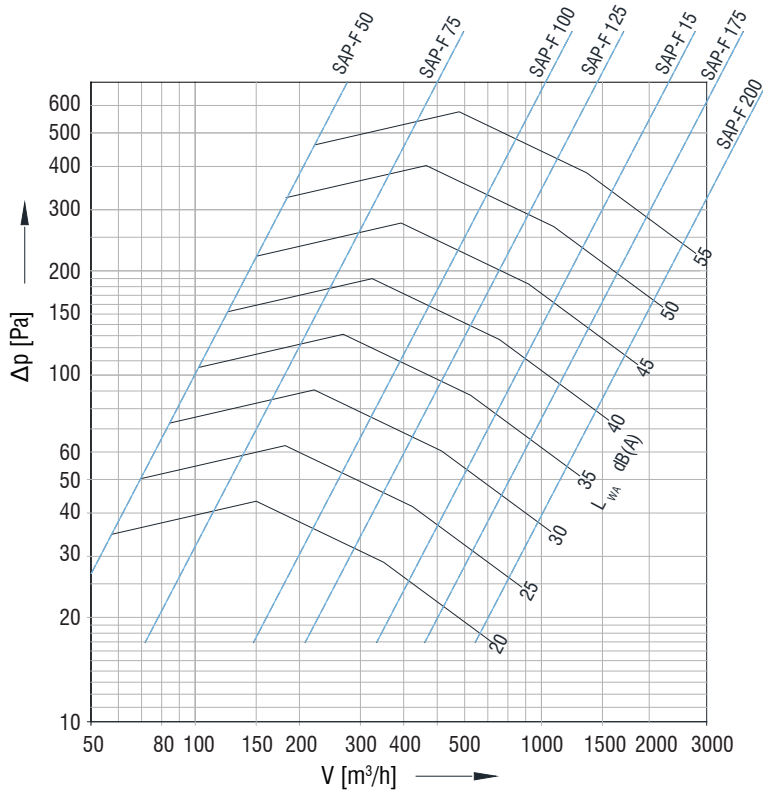

Axial installation SAP-Z

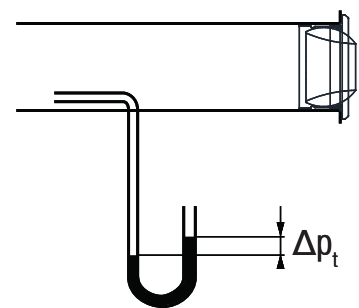
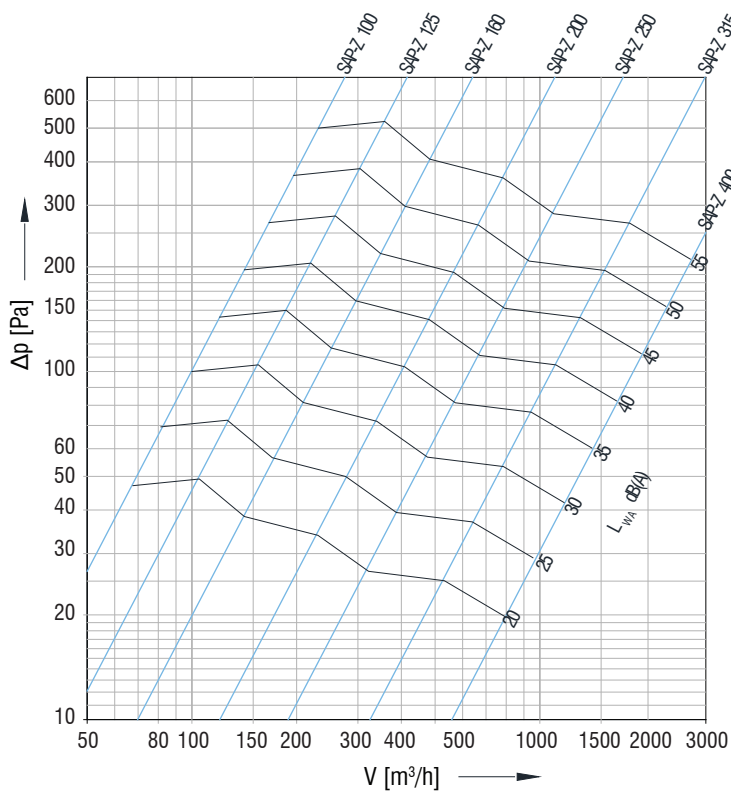

JET NOZZLES

Multiple duct installation SAP-F

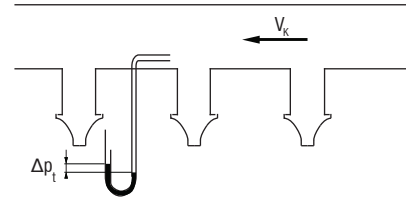
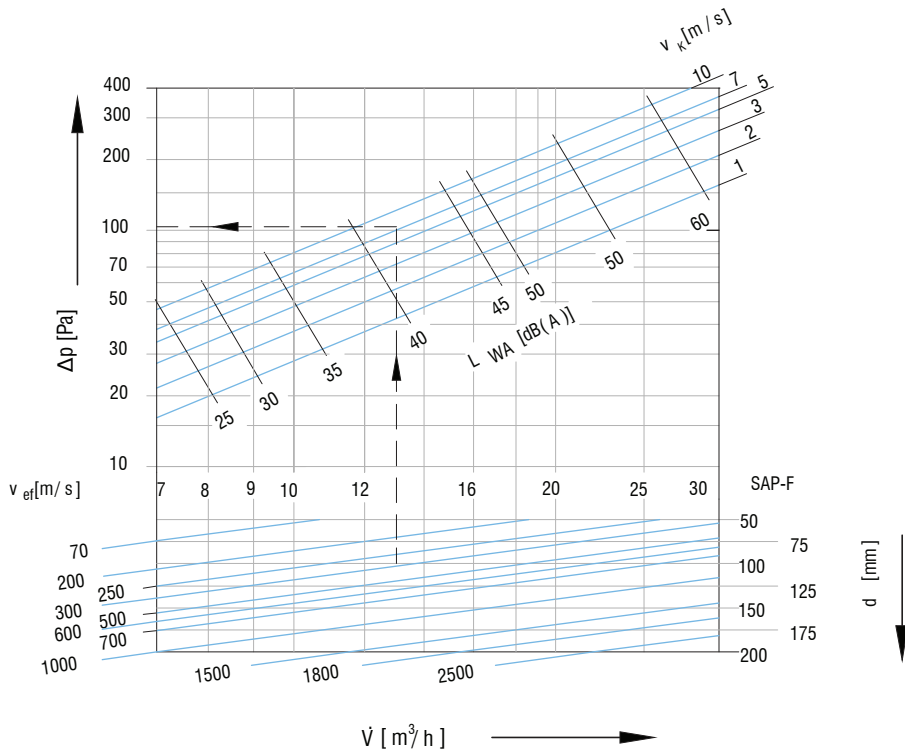

Multiple duct installation SAP-Z

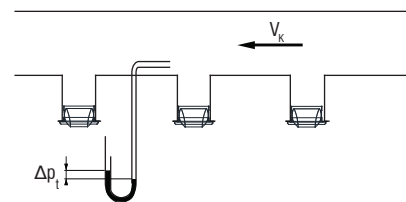
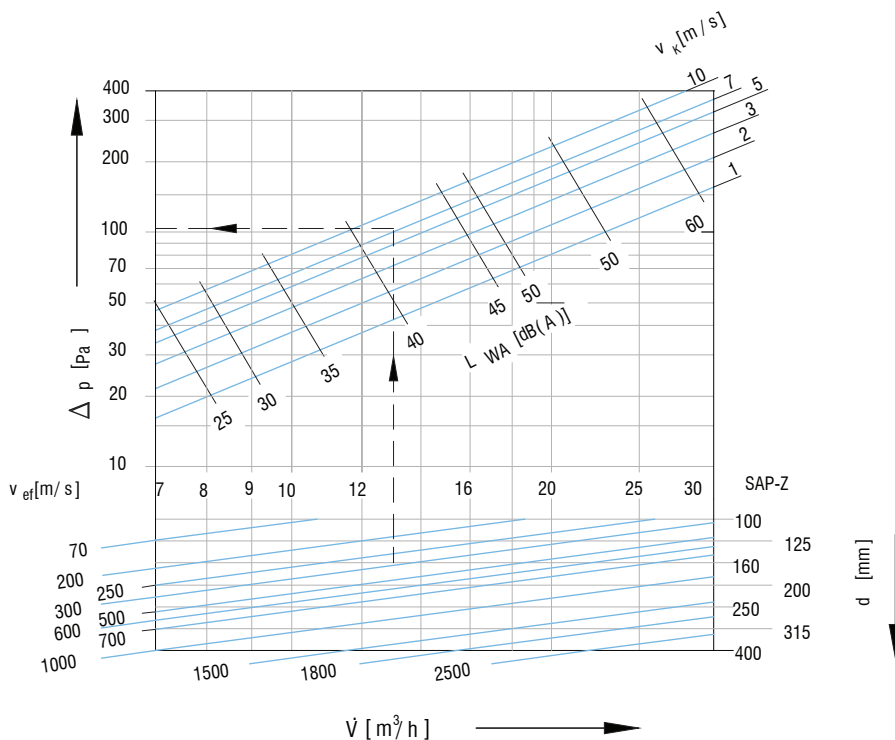

Correction values L_{WA} [dB(A)]

$\varnothing d$	Discharge angle	
	$\alpha = 0^\circ$	$\alpha = 30^\circ$
50	-6	-5
75	-3	-2
100	-2	0
125	1	2
150	3	4
175	4	6
200	5	7



For discharge angle $\pm 30^\circ$ pressure drop is multiplied by a factor of 1,2

Core velocity

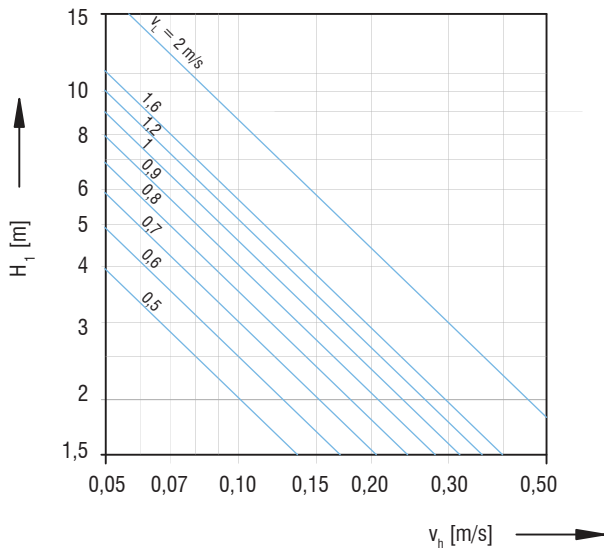

Temperature ratio

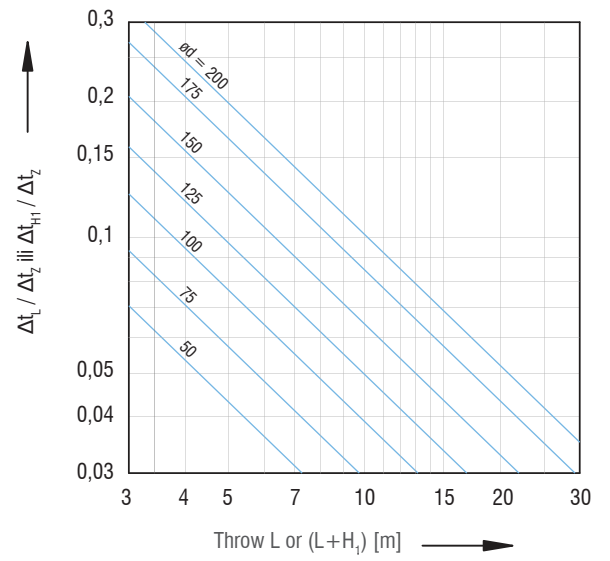

Induction

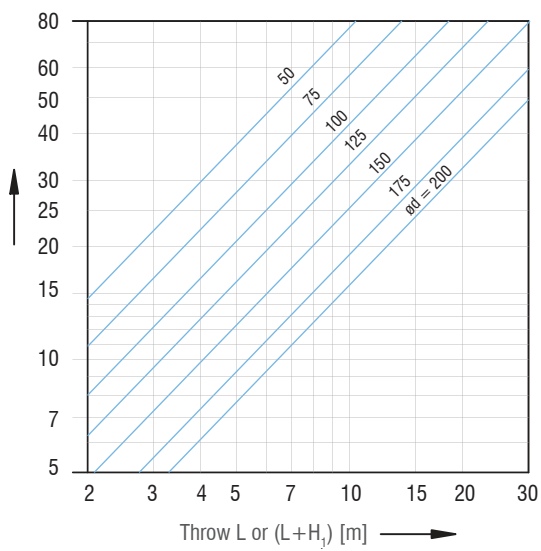

JET NOZZLES

MOTOR DRIVE

Standard motor drive version

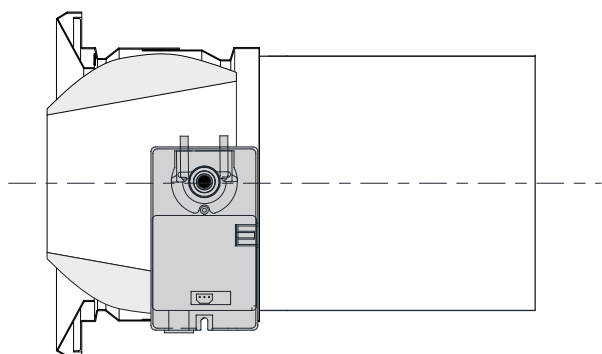

Ordering key

Jet nozzle **SAP - Z - 400 - M²30 - 1 - LO - RAL..**

Z - adjustable

F - fixed

(SAP-F - outer diameter)

(SAP-Z - inner diameter)

* **M²30-OZ** - motor drive 230V, two positions

* **M²30-K** - motor drive 230V, continuous

* **M²4-OZ** - motor drive 24V, two positions

* **M²4-K** - motor drive 24V, continuous

1 - standard motor drive version

Damper type **LO**

* Sizes 100 and 125 only with manual drive